



LONSDALEMETAL Co. LTD

London N17 9QU
 TEL: 020 8801 4221 FAX: 020 8801 1287
 Email: info@lonsdalemetal.co.uk
 www.lonsdalemetal.co.uk

DRAWING TITLE:

**SAFEGARDTG50 INTERMEDIATE
 SUPPORTED TRANSOM TO METAL**

SCALE: 1:2 AT A4

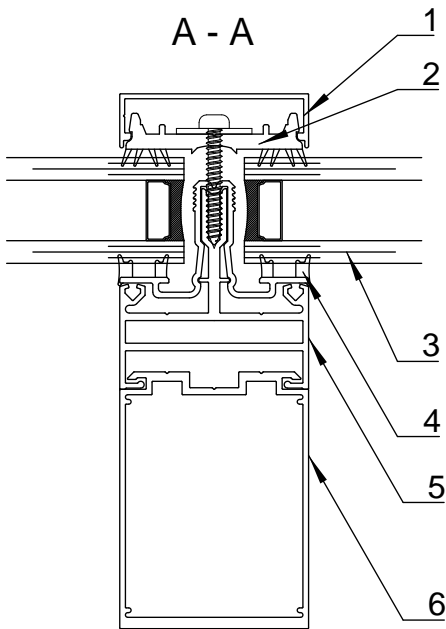

- 1. ALUMINIUM SNAP-ON COVER
- 2. PVC CO-EXTRUDED PRESSURE PLATE
- 3. STANDARD DGU 1.2 W*M²/K
- 4. PVC CO-EXTRUDED CARRIER RAIL THERMAL LINER
- 5. ALUMINIUM CARRIER RAIL
- 6. ALUMINIUM BOX SECTION
- 7. ALUMINIUM TRANSOM PRESSURE PLATE
- 8. SILICONE SEALANT
- 9. THERMALLY BROKEN ALUMINIUM TRANSOM POWDER COATED TO RAL 9005 MATT BLACK AS STANDARD
- 10. NEOPRENE/EPDM TAPE. 3X60MM
- 11. SELF-DRILLING SCREW
- 12. STEEL STRUCTURE (BY OTHERS)

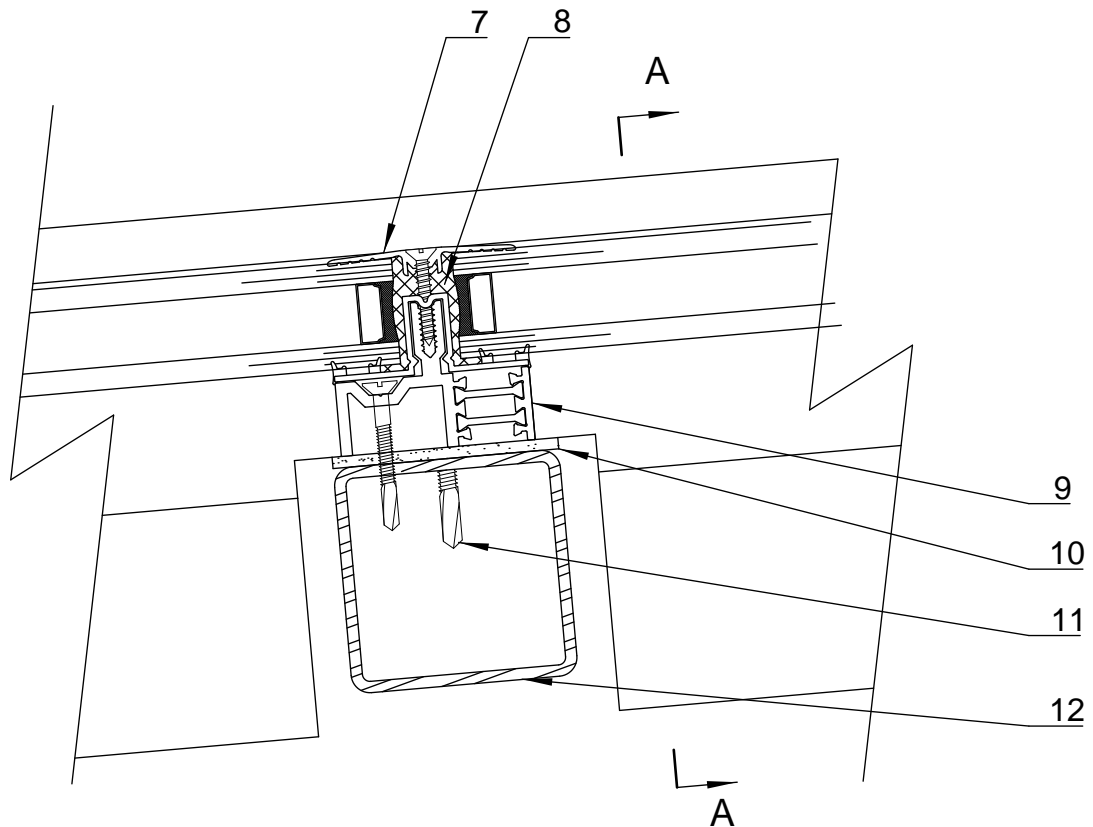

PROJECT:

**TECHNICAL CATALOGUE DETAIL
 SAFEGARDTG50**

| REV | DATE | |
|-----|------|--|
| | | |
| | | |
| | | |

DRAWN VM

DATE 07/2024

DRG. No. TG-5a